

# Data Mining, Big Data and Analytics

CSC 375 Fall 2017



Is this the place to learn about mining?

“To find signals in data, we must learn to reduce the noise ~ not just the noise that resides in the data, but also the noise that resides in us. It is nearly impossible for noisy minds to perceive anything but noise in data.”

— Stephen Few

## Related Fields

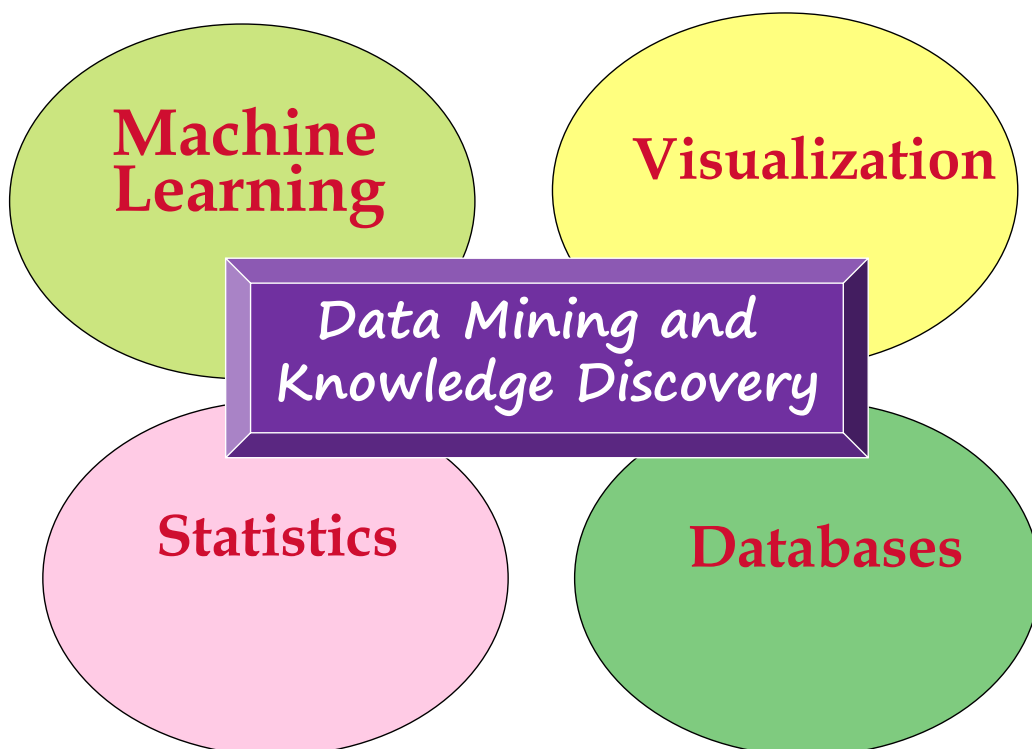

# Introduction

- **Big Data**
  - Data that exist in very large volumes and many different varieties (data types) and that need to be processed at a very high velocity (speed).
- **Analytics**
  - Systematic analysis and interpretation of data—typically using mathematical, statistical, and computational tools—to improve our understanding of a real-world domain.

## Big Data and Databases: Famous Quotes

“640K ought to be enough for anybody.”

*Bill Gates, 1981*

# Digitization of Everything: the Zettabytes are coming

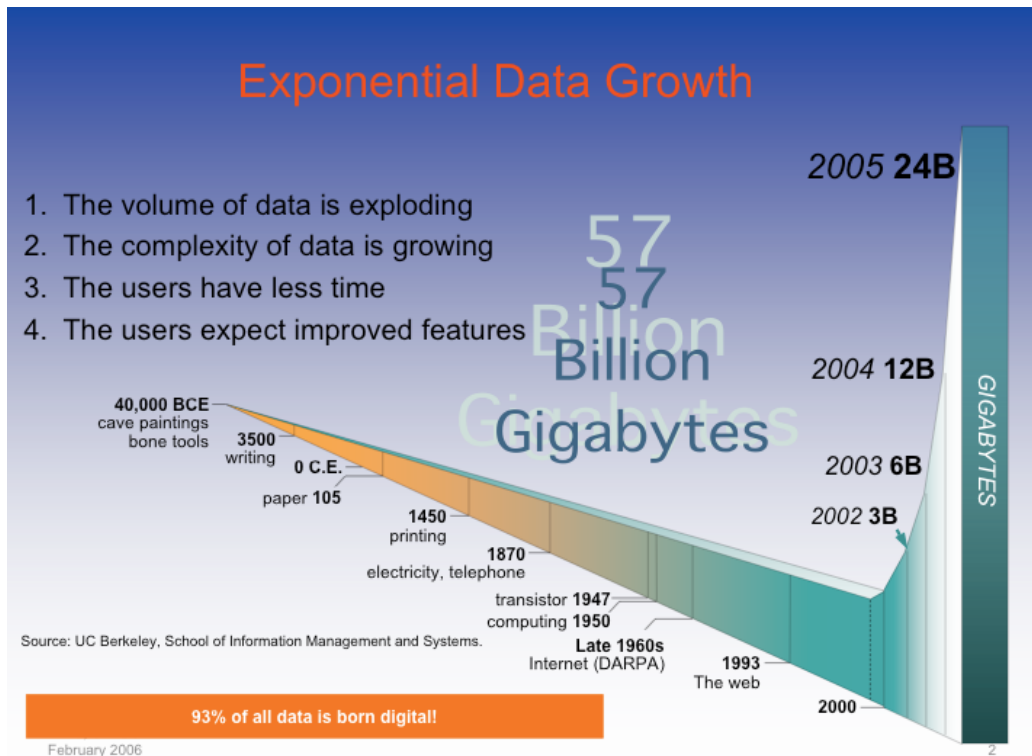

5

CSC375: Database Management Systems

## Characteristics of Big Data

### • The Five Vs of Big Data

- Volume – much larger quantity of data than typical for relational databases
- Variety – lots of different data types and formats
- Velocity – data comes at very fast rate (e.g. mobile sensors, web click stream)
- Veracity – traditional data quality methods don't apply; how to judge the data's accuracy and relevance?
- Value – big data is valuable to the bottom line, and for fostering good organizational actions and decisions

6

CSC375: Database Management Systems

# Characteristics of Big Data

- **Schema on Read, rather than Schema on Write**
  - Schema on Write– preexisting data model, how traditional databases are designed (relational databases)
  - Schema on Read – data model determined later, depends on how you want to use it (XML, JSON)
  - Capture and store the data, and worry about how you want to use it later
- **Data Lake**
  - A large integrated repository for internal and external data that does not follow a predefined schema
  - Capture everything, dive in anywhere, flexible access

## Examples of JSON and XML

### JSON Example

```
{ "products": [  
  { "number": 1, "name": "Zoom X", "Price": 10.00 },  
  { "number": 2, "name": "Wheel Z", "Price": 7.50 },  
  { "number": 3, "name": "Spring 10", "Price": 12.75 }  
]
```

JavaScript Object  
Notation

### XML Example

```
<products>  
  <product>  
    <number>1</number> <name>Zoom X</name> <price>10.00</price>  
  </product>  
  <product>  
    <number>2</number> <name>Wheel Z</name> <price>7.50</price>  
  </product>  
  <product>  
    <number>3</number> <name>Spring 10</name> <price>12.75</price>  
  </product>  
</products>
```

eXtensible Markup  
Language

# Schema on write vs. schema on read

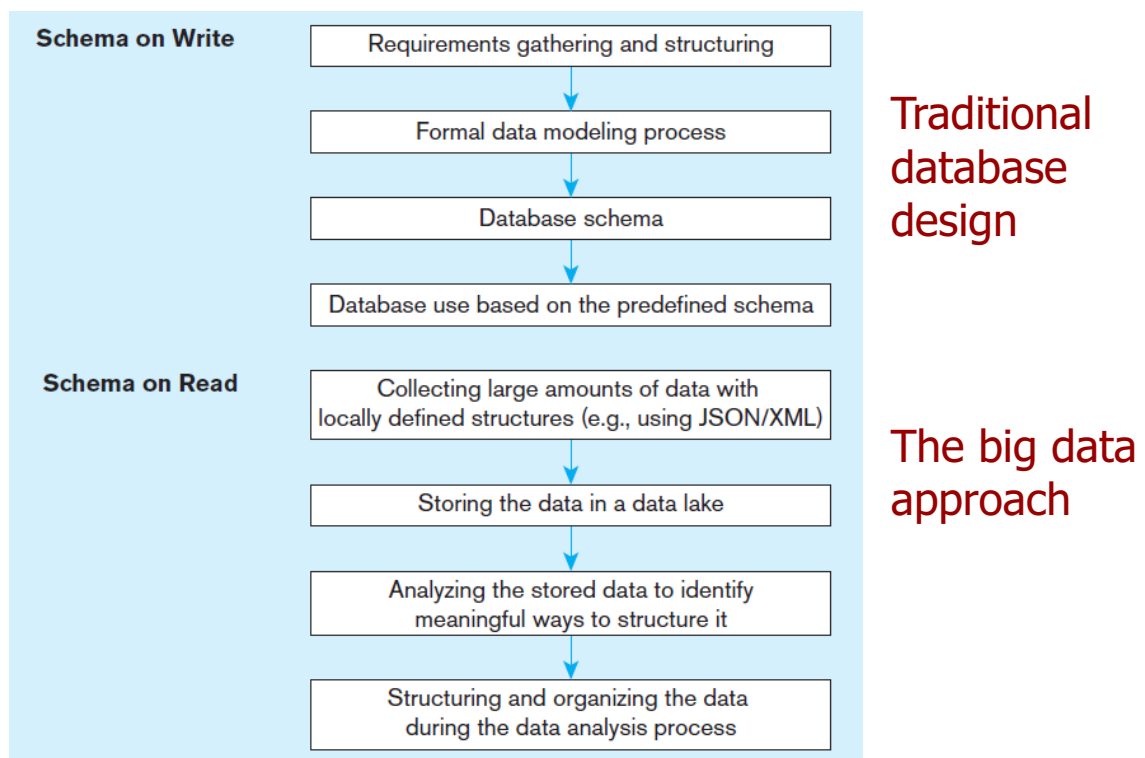

9

CSC375: Database Management Systems

## NoSQL

- **NoSQL = Not Only SQL**
- **A category of recently introduced data storage and retrieval technologies not based on the relational model**
- **Scaling out rather than scaling up**
- **Natural for a cloud environment**
- **Supports schema on read**
- **Largely open source**
- **Not ACID compliant!**
- **BASE – basically available, soft state, eventually consistent**

10

CSC375: Database Management Systems

# NoSQL Classifications

- **Key-value stores**
  - A simple pair of a key and an associated collection of values. Key is usually a string. Database has no knowledge of the structure or meaning of the values.
- **Document stores**
  - Like a key-value store, but “document” goes further than “value”. Document is structured so specific elements can be manipulated separately.
- **Wide-column stores**
  - Rows and columns. Distribution of data based on both key values (records) and columns, using “column groups/families”
- **Graph-oriented database**
  - Maintain information regarding the relationships between data items. Nodes with properties, Connections between nodes (relationships) can also have properties.

11

CSC375: Database Management Systems

## Four-part figure illustrating NoSQL databases

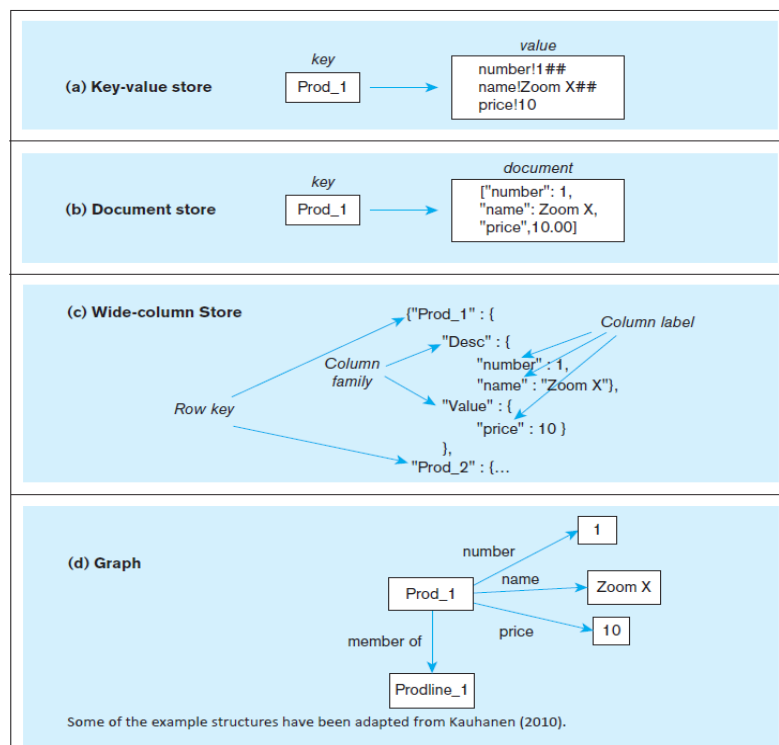

12

CSC375: Database Management Systems

# NoSQL Comparison

- **Redis – Key-value store DBMS**
- **MongoDB – document store DBMS**
- **Apache Cassandra – wide-column store DBMS**
- **Neo4j – graph DBMS**

13

CSC375: Database Management Systems

# NoSQL Comparison

**TABLE 11-2** Comparison of NoSQL Database Characteristics (Based on Scofield, 2010)

	Key-Value Store	Document Store	Column Oriented	Graph
Performance	high	high	high	variable
Scalability	high	variable/high	high	variable
Flexibility	high	high	moderate	high
Complexity	none	low	low	high
Functionality	variable	variable (low)	minimal	graph theory

Source: <http://www.slideshare.net/bScofield/nosql-codemash-2010>

Courtesy of Ben Scofield.

14

CSC375: Database Management Systems

# Hadoop

- **Hadoop is an open source implementation framework of MapReduce**
- **MapReduce is an algorithm for massive parallel processing of various types of computing tasks**
- **Hadoop Distributed File System (HDFS) is a file system designed for managing a large number of potentially very large files in a highly distributed environment**
- **Hadoop is the most talked about Big-Data data management product today**
- **Hadoop is a good way to take a big problem and allow many computers to work on it simultaneously**

15

CSC375: Database Management Systems

## Hadoop Distributed File System (HDFS)

- **A file system, not a DBMS, not relational**
- **Breaks data into **blocks** and distributes them on various computers (**nodes**) throughout a Hadoop **cluster****
- **Each cluster consists of a **NameNode** (master server) and some **DataNodes** (slaves)**
- **Overall control through **YARN** ("yet another resource allocator")**
- **No updates to existing data in files, just appending to files**
- **"Move computation to the data", not vice versa**

16

CSC375: Database Management Systems



## Four part figure illustrating NoSQL databases

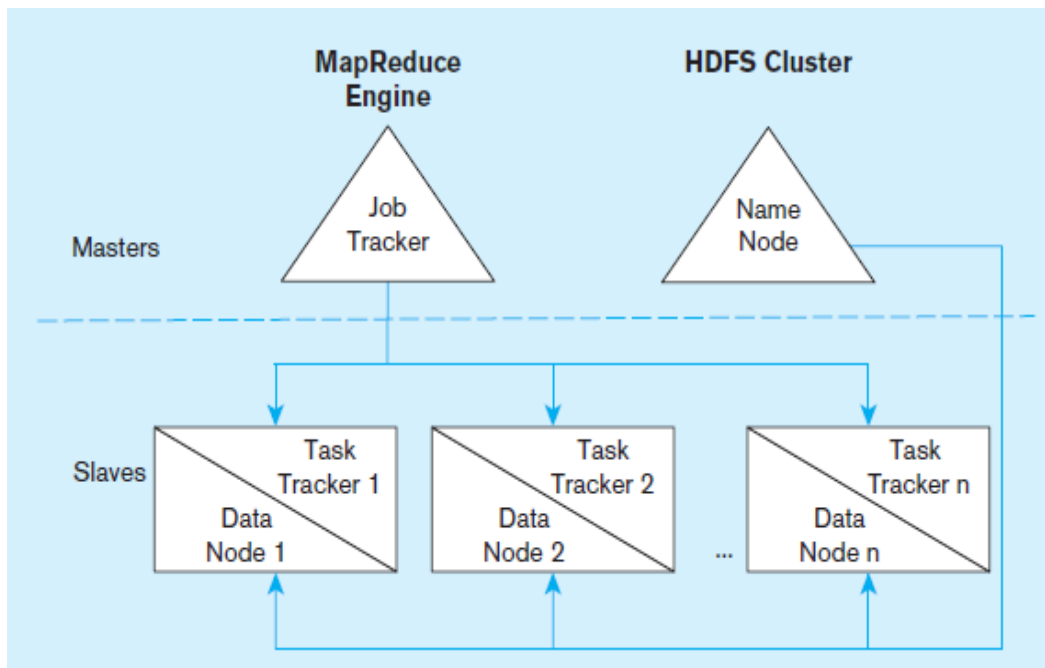

17

CSC375: Database Management Systems

## MapReduce

- **Enables parallelization of data storage and computational problem solving in an environment consisting of a large number of commodity servers**
- **Programmers don't have to be experts at parallel processing**
- **Core idea – divide a computing task so that a multiple nodes can work on it at the same time**
- **Each node works on local data doing local processing.**
- **Two stages:**
  - **Map** stage – divide for local processing
  - **Reduce** stage – integrate the results of the individual map processes

18

CSC375: Database Management Systems

# Schematic representation of MapReduce

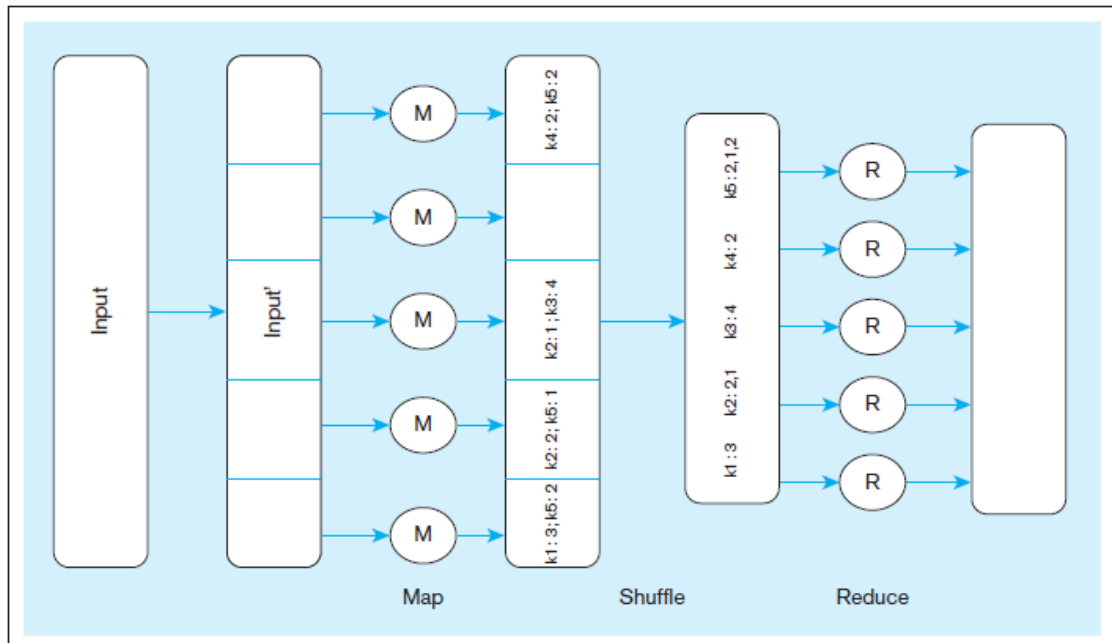

MapReduce: Simplified Data Processing on Large Clusters, Jeff Dean, Sanjay Ghemawat, Google, Inc., <http://research.google.com/archive/mapreduce-osdi04-slides/index-auto-0007.html>. Courtesy of the authors. 19

CSC375: Database Management Systems

## Other Hadoop Components

- **Pig**
  - A tool that integrates a scripting language and an execution environment intended to simplify the use of MapReduce
  - Useful development tool
- **Hive**
  - An Apache project that supports the management and querying of large data sets using HiveQL, an SQL-like language that provides a declarative interface for managing data stored in Hadoop.
  - Useful for ETL tasks
- **HBase**
  - A wide-column store database that runs on top of HDFS
  - Not as popular as Cassandra

# Integrated Analytics and Data Science Platforms

- **Some vendors are bringing together traditional data warehousing and big data capabilities**
- **Examples**
  - HP HSAVEN – Hewlett Packard technologies combined with Hadoop open source and an analytics engine
  - Teradata Aster – integrate SQL, graph analysis, MapReduce, R
  - IBM Big Data Platform – combine IBM technologies with Hadoop, JSON Query Language (JAQL), DB2, Netezza

21

CSC375: Database Management Systems

## Integrated Data Architecture

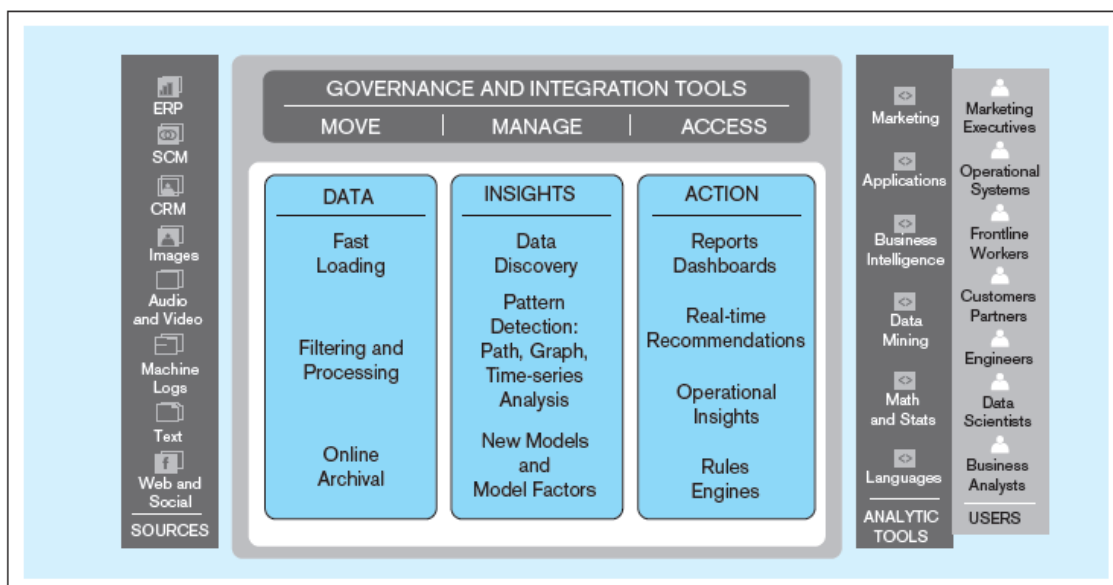

UNIFIED DATA ARCHITECTURE, 10.14, EB 7805, <http://www.teradata.com/Resources/White-Papers/Teradata-Unified-Data-Architecture-in-Action>. Courtesy of Teradata Corporation

Teradata Unified Data Architecture – logical view

22

CSC375: Database Management Systems

# Integrated Data Architecture

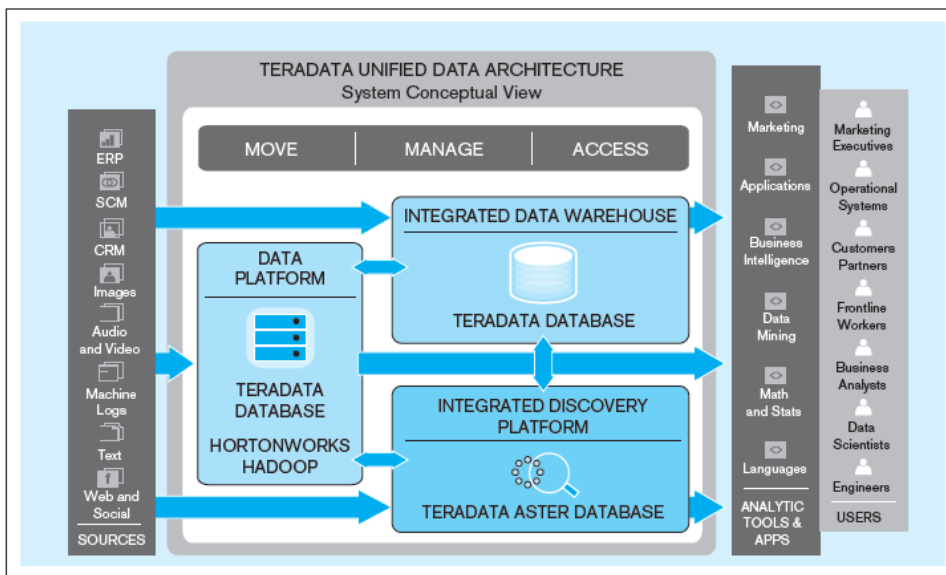

FIGURE 11-9 Teradata Unified Data Architecture – system conceptual view

UNIFIED DATA ARCHITECTURE, 10.14, EB 7805, <http://www.teradata.com/Resources/White-Papers/Teradata-Unified-Data-Architecture-in-Action>. Courtesy of Teradata Corporation

## Teradata Unified Data Architecture – system conceptual view

23

CSC375: Database Management Systems

# Analytics

- **Historical precedents to analytics:**
  - Management information systems (MIS) → Decision Support Systems (DSS) → Executive Information Systems (EIS)
  - DSS idea evolved into Business Intelligence (BI)
- **Business Intelligence – a set of methodologies, processes, architectures, and technologies that transform raw data into meaningful and useful information.**
- **Analytics encompasses more than BI**
  - Umbrella term that includes BI
  - Transform data to useful form
  - Infrastructure for analysis
  - Data cleanup processes
  - User interfaces

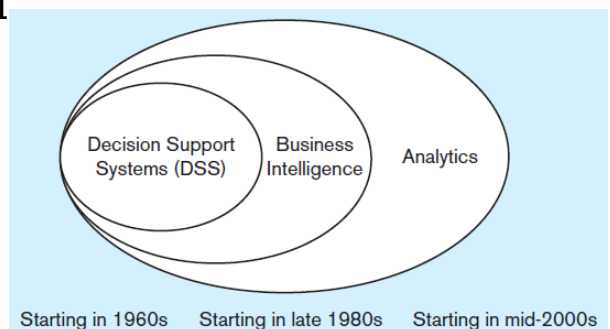

24

CSC375: Database Management Systems

# Types of Analytics

- **Descriptive analytics** – describes the past status of the domain of interest using a variety of tools through techniques such as reporting, data visualization, dashboards, and scorecards
- **Predictive analytics** – applies statistical and computational methods and models to data regarding past and current events to predict what might happen in the future
- **Prescriptive analytics** – uses results of predictive analytics along with optimization and simulation tools to recommend actions that will lead to a desired outcome

25

CSC375: Database Management Systems

## Generations of Business Intelligence and Analytics

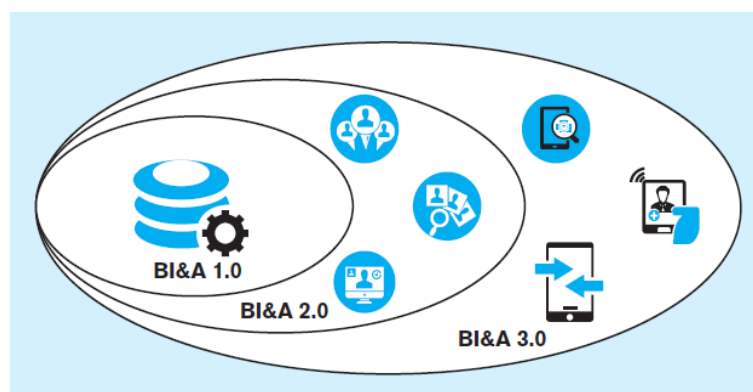

*Adapted from Chen et al., 2012*

### BI&A 1.0

Focus on structured quantitative data largely from relational databases

### BI&A 2.0

Include data from the Web (web interaction logs, customer reviews, social media)

### BI&A 3.0

Include data from mobile devices, (location, sensors, etc.) as well as Internet of Things

26

CSC375: Database Management Systems

# Use of Descriptive Analytics

- **Descriptive analytics was the original emphasis of BI**
- **Reporting of aggregate quantitative query results**
- **Tabular or data visualization displays**
- **Dashboard – a few key indicators**
- **Scorecard – like a dashboard, but broader range**
- **OLAP – online analytical processing**

27

CSC375: Database Management Systems

## SQL OLAP Querying

- **SQL is generally not an analytic language, but it can be used for analysis.**
- **However, OLAP extensions to SQL make this easier.**
- **OLAP queries should support:**
  - Categorization – e.g. group data by dimension characteristics
  - Aggregation – e.g. create averages per category
  - Ranking – e.g. find customer in some category with highest average monthly sales

28

CSC375: Database Management Systems

# Regular SQL Query

TOP 1

```
SELECT P1.ProductId, ProductDescription, C1.CustomerId,
       CustomerName, SUM(OL1.OrderedQuantity) AS TotOrdered
FROM Customer_T AS C1, Product_T AS P1, OrderLine_T
     AS OL1, Order_T AS O1
WHERE C1.CustomerId = O1.CustomerId
      AND O1.OrderId = OL1.OrderId
      AND OL1.ProductId = P1.ProductId
GROUP BY P1.ProductId, ProductDescription,
         C1.CustomerId, CustomerName
HAVING TotOrdered >= ALL
       (SELECT SUM(OL2.OrderedQuantity)
        FROM OrderLine_T AS OL2, Order_T AS O2
        WHERE OL2.ProductId = P1.ProductId
              AND OL2.OrderId = O2.OrderId
              AND O2.CustomerId <> C1.CustomerId
        GROUP BY O2.CustomerId)
ORDER BY P1.ProductId;
```

Can be  
removed

29

# OLAP SQL Query

Consider a SalesHistory table (columns TerritoryID, Quarter, and Sales) and the desire to show a three-quarter moving average of sales.

```
SELECT TerritoryID, Quarter, Sales,
       AVG(Sales) OVER (PARTITION BY TerritoryID
                        ORDER BY Quarter ROWS 2 PRECEDING) AS 3QtrAverage
FROM SalesHistory;
```

TerritoryID	Quarter	Sales	3QtrAverage
Atlantic	1	20	20
Atlantic	2	10	15
Atlantic	3	6	12
Atlantic	4	29	15
East	1	5	5
East	2	7	6
East	3	12	8
East	4	11	10
...			

OVER (also called WINDOW) is a special clause that provide a “sliding view” of rows from a query. PARTITION BY is like a GROUP by for OVER.

30

# Online Analytical Processing (OLAP) Tools

- **Online Analytical Processing (OLAP)** -- the use of a set of graphical tools that provides users with multidimensional views of their data and allows them to analyze the data using simple windowing techniques
- **Relational OLAP (ROLAP)** – OLAP tools that view the database as a traditional relational database in either a star schema or other normalized or denormalized set of tables
- **Multidimensional OLAP (MOLAP)** –OLAP tools that load data into an intermediate structure, usually a three- or higher-dimensional array.

31

CSC375: Database Management Systems

## Slicing a data cube

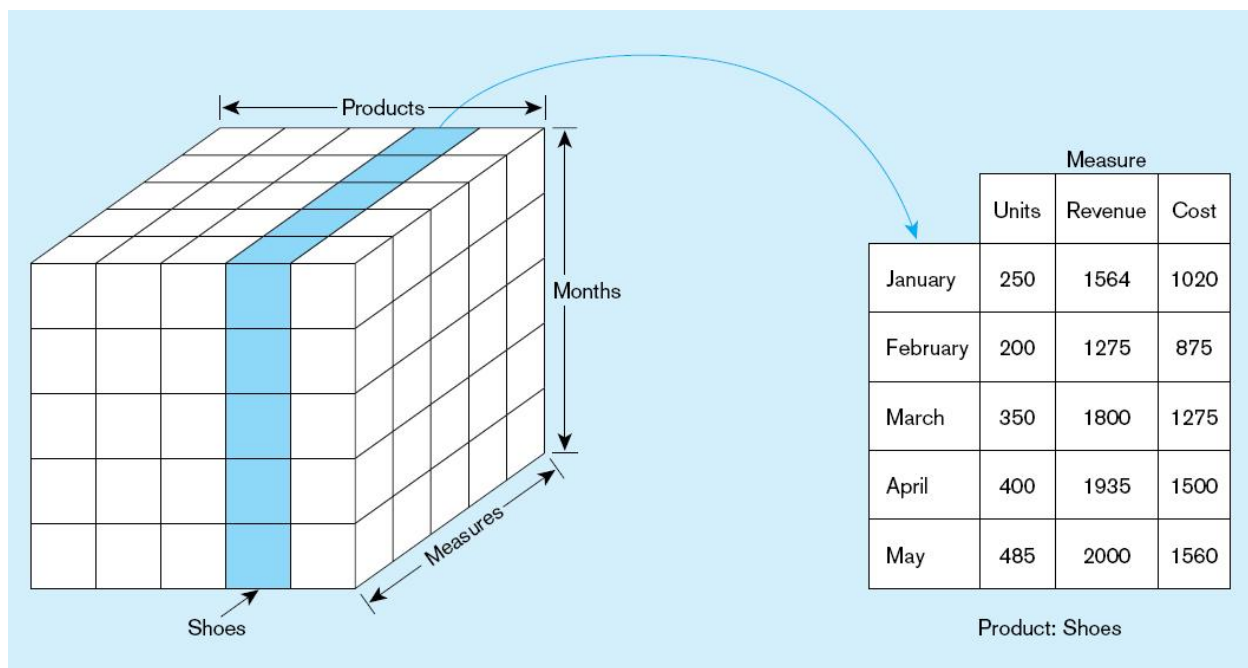

Slicing, dicing, pivoting, and drill-down are useful cube operations

32

CSC375: Database Management Systems



## Example of drill-down

*Starting with summary data, users can obtain details for particular cells.*

Brand	Package size	Sales
SofTowel	2-pack	\$75
SofTowel	3-pack	\$100
SofTowel	6-pack	\$50

## Summary report

Brand	Package size	Color	Sales
SofTowel	2-pack	White	\$30
SofTowel	2-pack	Yellow	\$25
SofTowel	2-pack	Pink	\$20
SofTowel	3-pack	White	\$50
SofTowel	3-pack	Green	\$25
SofTowel	3-pack	Yellow	\$25
SofTowel	6-pack	White	\$30
SofTowel	6-pack	Yellow	\$20

## Drill-down with color added 33

CSC375: Database Management Systems

**Sample pivot table with four dimensions:  
Country (pages), Resort Name (rows), Travel Method, and No. of Days (columns)**

Country		(All)															
Average of Price	Resort Name	Travel Method			Coach Total	No. of Days										Plane Total	
		Coach	5	7		6	7	8	10	14	16	21	32	60			
	Aviomore			135	135												
	Barcelona																
	Black Forest	69			69												
	Cork						269										269
	Grand Canyon														1128		1128
	Great Barrier Reef													750			750
	Lake Geneva						699										699
	London																
	Los Angeles						295			375							335
	Lyon									399							399
	Malaga											234					234
	Nerja						198				255						226.5
	Nice						289										289
	Paris-Euro Disney																
	Prague			95	95												
	Seville								199								199
	Skiathos													429			429
	Grand Total	69	95	135	99.66666667	198	292	484	199	343	234	429	750	1128			424.5384615

*Although the screen is only two dimensions, you can include more dimensions by combining multiple in a row or column, and by including paging*

34

CSC375: Database Management Systems

# Data Visualization

- **Representation of data in graphical and multimedia formats for human analysis**
- **"A picture tells a thousand words"**
- **Without showing precise values, graphs and charts can depict relationships in the data**
- **Often used in dashboards, as shown in next slide**

35

CSC375: Database Management Systems

## Business Performance Mgmt (BPM): Sample Dashboard

- **BPM systems allow managers to:**
  - Measure,
  - Monitor
  - Manage key activities and processes to achieve organizational goals
- **Dashboards are often used to provide an information system in support of BPM.**

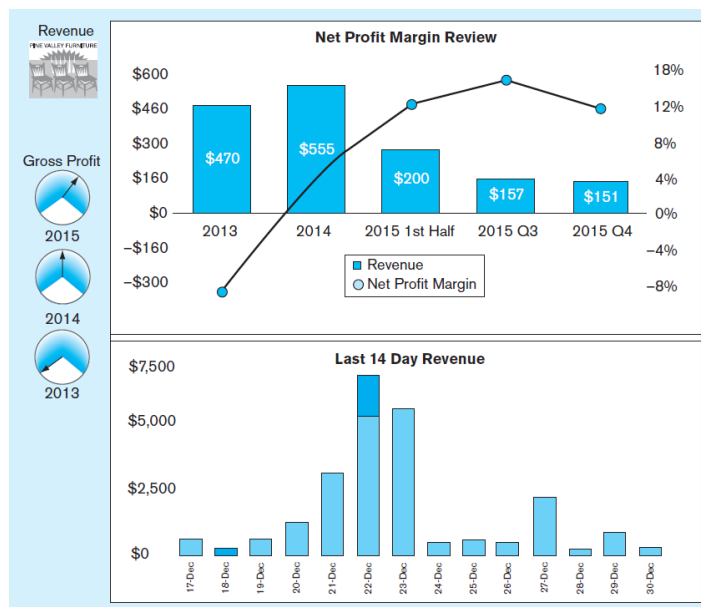

*Charts like these are examples of data visualization, the representation of data in graphical and multimedia formats for human analysis.*

36

CSC375: Database Management Systems

# Predictive Analytics

- **Statistical and computational methods that use data regarding past and current events to form models regarding what might happen in the future**
- **Examples: classification trees, linear and logistic regression analysis, machine learning, neural networks, time series analysis, Bayesian modeling**

37

CSC375: Database Management Systems

# Data Mining Tools

- **Knowledge discovery using a sophisticated blend of techniques from traditional statistics, artificial intelligence, and computer graphics**
- **Goals:**
  - Explanatory – explain observed events or conditions
  - Confirmatory – confirm hypotheses
  - Exploratory – analyze data for new or unexpected relationships
- **Text mining – Discovering meaningful information algorithmically based on computational analysis of unstructured textual information**

38

CSC375: Database Management Systems

**TABLE 11-4 Data-Mining Techniques**

Technique	Function
Regression	Test or discover relationships from historical data
Decision tree induction	Test or discover if . . . then rules for decision propensity
Clustering and signal processing	Discover subgroups or segments
Affinity	Discover strong mutual relationships
Sequence association	Discover cycles of events and behaviors
Case-based reasoning	Derive rules from real-world case examples
Rule discovery	Search for patterns and correlations in large data sets
Fractals	Compress large databases without losing information
Neural nets	Develop predictive models based on principles modeled after the human brain

39

CSC375: Database Management Systems

**TABLE 11-5 Typical Data-Mining Applications**

Data-Mining Application	Example
Profiling populations	Developing profiles of high-value customers, credit risks, and credit-card fraud.
Analysis of business trends	Identifying markets with above-average (or below-average) growth.
Target marketing	Identifying customers (or customer segments) for promotional activity.
Usage analysis	Identifying usage patterns for products and services.
Campaign effectiveness	Comparing campaign strategies for effectiveness.
Product affinity	Identifying products that are purchased concurrently or identifying the characteristics of shoppers for certain product groups.
Customer retention and churn	Examining the behavior of customers who have left for competitors to prevent remaining customers from leaving.
Profitability analysis	Determining which customers are profitable, given the total set of activities the customer has with the organization.
Customer value analysis	Determining where valuable customers are at different stages in their life.
Upselling	Identifying new products or services to sell to a customer based upon critical events and life-style changes.

*Source:* Based on Dyché (2000).

40

CSC375: Database Management Systems

# KNIME Example of Predictive Analytics

- **Credit scoring**
  - Takes past financial data to produce a credit score
  - Starts with decision trees, neural networks, and support vector machine (SVM) algorithms for initial model
  - Next uses Predictive Modeling Markup Language (PMML)
- **Marketing**
  - Churn analysis – predicting which customers will leave using clustering via k-means algorithm
  - Social media analysis using association rules

41

CSC375: Database Management Systems

## Use of Prescriptive Analytics

- **Use of optimization and simulation tools for prescribing the best action to take**
- **Example applications**
  - Making trading decisions in securities and stock market
  - Making pricing decisions for airlines and hotels
  - Making product recommendations (e.g. Amazon and Netflix)
- **Often requires predictive analytics and game theory**

42

CSC375: Database Management Systems

# Analytics Data Management Infrastructure

- **Important criteria: scalability, parallelism, low latency, and data optimization**
- **These criteria ensure speed, availability, and access**

**TABLE 11-6** Technologies Enabling Infrastructure Advances in Data Management

Massively parallel processing (MPP)	Instead of relying on a single processor, MPP divides a computing task (such as query processing) between multiple processors, speeding it up significantly.
In-memory DBMSs	In-memory DBMSs keep the entire database in primary memory, thus enabling significantly faster processing.
In-database analytics	If analytical functions are integrated directly to the DBMS, there is no need to move large quantities of data to separate analytics tools for processing.
Columnar DBMSs	They reorient the data in the storage structures, leading to efficiencies in many data warehousing and other analytics applications. 43

CSC375: Database Management Systems

## Big Data and Analytics Impact: Applications

- **Business**
- **E-government and politics**
- **Science and technology**
- **Smart health and well-being**
- **Security and public safety**

# Big Data and Analytics Impact: Social Implications

- **Personal privacy vs. collective benefit**
- **Ownership and access**
- **Data/algorithm quality and reuse**
- **Transparency and validation**
- **Demands for workforce capabilities and education**

*Slides adapted from: Jeff Hoffer, Ramesh Venkataraman, Heikki Topi*

